

Simulation Model Analysis of AMHS w/Area Elevators for an 8 inch Wafer FAB

Donald W. Collins, Luc D’Arcy Collins and Bob Franklin

donald.collins@asu.edu.us
 Arizona State University East
 7442 E. Tillman Ave., 3030
 Mesa, Arizona, US 85212
 T: 480-727-1187 F: 480-727-1549

darcy@acadzinc.com
 ACADZ inc.
 3104, E. Camelback #718
 Phoenix, AZ 85012
 T: 602-212-2485 F: 602-212-9344

bobf@intrabayautomation.com
 Intrabay Automation
 4 Harris Court
 Monterey, CA 93940
 T: 831-375-4555 F: 831-375-4666

■ Manufacturing Control and Execution

ABSTRACT: This paper describes the logic and assumptions used in building a simulation model of an Automated Material Handling System (AMHS) for an eight inch Wafer FAB. The model includes the ability to make changes to the area stocker layout, number of area stockers, number of loops, number of cars and or the number of Lot moves.

This simulation model is used to determine if the Area Stockers can handle the quantities of Lots per hour required by a From-To-Table “customer” requirements listed in Table 1.

The AMHS model and trial simulation software described in detail in this paper is available at ACADZ web site’s “Demo Model” section (www.acadzinc.com) for evaluation purposes. The model runs on Extend™ simulation software and connects dynamically to an Excel database to send and receive data providing statistical results for decision making and evaluation purposes (see the send and receive icons in Figure 1).

The Simulation Model Logic

The simulation model was developed using Icon based simulation software. The “Lot” or “Cassette” arrival rate and departure rate from a machine to another machine is collected and placed on a large detailed From-To Table listing all moves. This From-To Table listing all moves will be used to calculate stocker and loop usage requirements for the FAB area. It is essential to determine all moves that will take place in a FAB as accurately as possible as this will determine the number of stockers and placement of train track loops. To ensure accuracy of future move estimates, sections of the FAB are modeled where there will be changes in automation or processing equipment. Once all moves are determined, a From-To Table for Area Stockers is created from the large detailed From-To Table listing all moves taking into account the flexibility of the fab layout, each Stocker’s area work requirement and the AMHS capabilities.

Example Model of a section of the FAB where changes affect future moves estimates

Here the “Lot” or “Cassette” arrival for one such area is described. The Products were counted and the process times are set for the different machine groups (Figure 1).

Oral Presentation

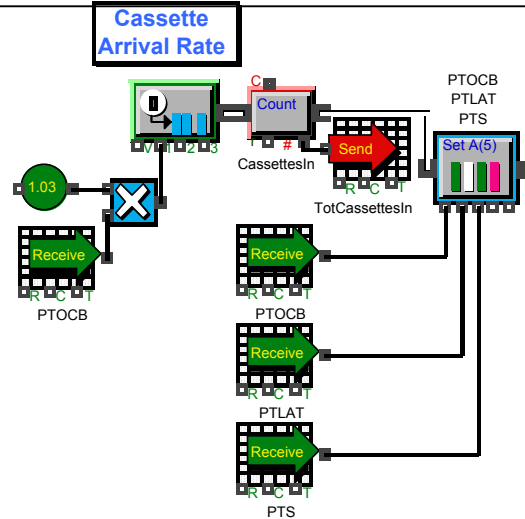

Figure 1. Arrival Rate of Products to a Stocker location

The next set of Icons (Figure 2.) represent the Clean Bath Area where the Cassettes are batched in groups of 4 before the Clean Bath and unbatched after they have been processed. There are five Vertical Actuators to take the Cassettes one by one to a Horizontal Conveyor belt (Figure 3.).

The Horizontal Conveyor (Figure 3.) receives the Cassettes in Batches of eight from each of the five baths and transfers the Cassettes to the 90-degree carousel (Figure 4.).

The Carousel (Figure 4.) receives the Cassettes one by one and turns 90-degrees and sends the Cassettes to the 20 Station Horizontal Actuator, which serves twelve Laser Ablation Tools (Figure 5.) and the Sputterer Stations. After the Cassette Lots leave the Sputterer Station they travel by the overhead AHMS that serve the six Stockers. Stocker 1 serves the Etch Bay and Furnace area, Stocker 2 serves the Implant area, Stocker 3 serves the Test Area, while Stocker 4 serves the Chemical Mechanical Polishing, Chemical Vapor Deposition and Lithography areas. This is the busiest area in the FAB know as the bottleneck area. Stocker 5 serves as the Probe and Test area and Stocker 6 serves the additional Etch, Furnace and Wet Clean areas.

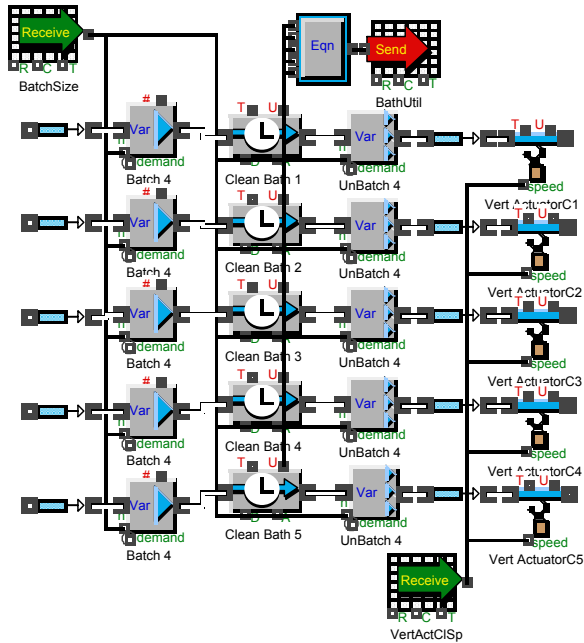

Figure 2. Clean Bath Process Group

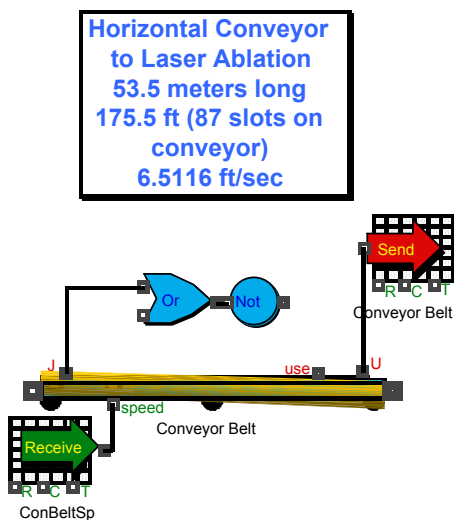

Figure 3. Horizontal Conveyor

Now this model of the subsection of the FAB is run to determine the estimated future moves for this area. These moves are incorporated into the From-To Tables listing all moves. To develop this table, you must understand the following in detail:

1. Determination of the requirement for flexibility of the layout.
2. Determine the required transport work requirement From-To each bay (or FAB section) using From-To Tables listing all moves.
3. Select AMHS Equipment and Model several mock layouts.

When selecting AMHS Equipment the following items need to be considered:

- number of stockers and their placement

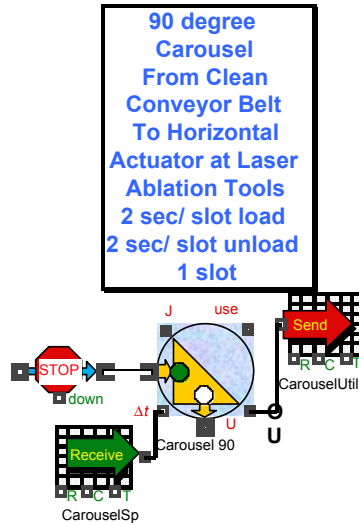

Figure 4. 90-Degree Carousel

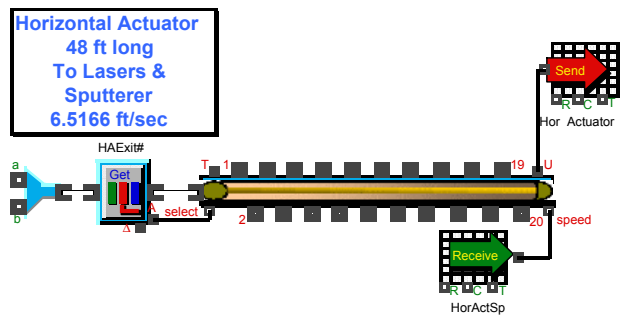

Figure 5. Twenty Station Horizontal Actuator

- number of loops and there placement
- number of trains(and cars per train) for each loop
- number of elevators if applicable
- number of turntables
- other if applicable

In the next section we have created a From-To Table that summarizes the required transport work requirement From-To each bay (or FAB section) using From-To Tables listing all moves. Now we will look at our assumptions to select the AMHS Equipment.

Stocker		2	3	4	5	1	6	
	Floor	H17	H16A	H16B	H15-3	H15-4	H15-5	Total
2	H17	16	16	16	1	1	1	34
3	H16A	16	2	2	6	6	6	34
4	H16B	16	2	6	6	6	6	34
5	H15-3	1	6	6	11	11	10	34
1	H15-4	1	6	6	11	10	10	34
6	H15-5	1	6	6	10	10	10	33
	Total	34	34	34	34	34	33	203

Table 1. From-To-Table (Customer)

Assumptions to select the AMHS Equipment:

- Lots quantities used come from a 15 X15 table; From-To Tables listing all moves

- Lots moves between area stockers (see Table 1) and number of area stockers assigned 1 to 6
- Train travel speed is 40 cm/sec average
- Area stoker transfer time to and from trains (minutes) Max is 1 minute 45 seconds/train)
- 6 cars per train
- Travel distances as per .DWG AutoCAD file and as described below in Figure 6.

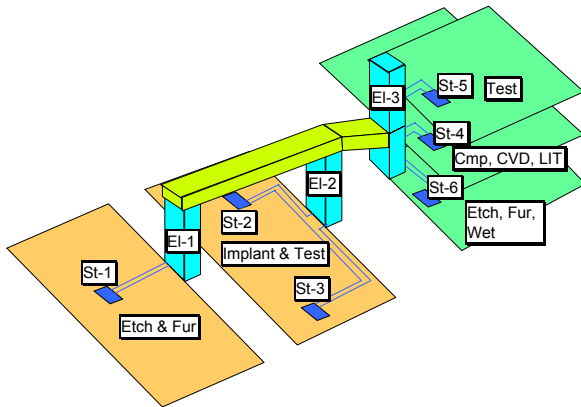

Figure 6. FAB Layout Diagram

- Magistrale or Area elevators holds one train of 6 cars
- Magistrale or Area elevators up or down stroke is 5 seconds
- Magistrale or Area elevators load is 5 seconds
- Magistrale or Area elevators unload is 5 seconds
- Area elevator total move (upstroke or down-stroke + load plus unload) is 15 seconds
- The maximum number of lots a train can hold is 6
- 1 train maximum in the unload area
- 3 trains maximum in the load area
- Total of 4 trains in the load & unload area
- All trains should remain on the track of a loop at all time
- Trains move in only one direction on the track (counter clockwise when looking at the AutoCAD file)
- 25 seconds for an operator to manually unload and load a train
- Roll in 10 seconds
- Transfer 5 seconds
- Roll out 10 seconds

Above (Figure 6.) is the FAB building layout, location of area stockers, Magistrale elevators and loops. Here we have assigned numbers St-1 through St-6 for each of the area stockers.

Questions to be answered:

This simulation model is to determine if the Area Stockers can handle the quantities of Lots required on From-To-Table requirements

AMHS for an 8 inch Wafer FAB. We wish to emphasize that the model assumption of how material is processed over time in the FAB is based on the From-To Table for Area Stockers revised by ACADZ (Table 2.). The From-To Table for Area Stockers was created based on the From-To Tables listing all moves.

Floor	Stocker	H15-4	H17	H16	H16	H15-3	H15-5	Total
H15-4	1	0	6	3	4	1	1	16
H17	2	6	0	7	8	6	6	33
H16	3	3	7	0	5	3	3	20
H16	4	4	8	5	0	4	4	25
H15-3	5	1	6	3	4	0	1	16
H15-5	6	1	6	3	4	1	0	15
	Total	16	33	20	25	16	15	124

Table 2. Actual From-To-Table (ACADZ)

Note: The model results confirm the number of trains needed to service the six Area Stockers each hour to meet requirements set by “customer”. This is based on the gross requirement of lots on the From-To Tables listing all moves from the “customer”.

The table sent by the “customer” is based on their current production mix. If the “customer” changes the current production mix a new From-To table should be created and an update of the simulation model can be done for the six area stockers. Actual moves of lots for the whole FAB may differ from the above assumptions, and should be updated for this model to reflect current use.

Model assumptions from “customer”:

- Average Service of a 6 car train at an Area Stocker = 10 seconds = 0.1666 minutes
- 60 minutes /0.1666 minutes = 360 trains/ hour
- (The average service assumption above is that a six car train will not be full and there will be an operator to remove and place lots on the trains when required, therefore 10 seconds)
- Average service of a 6 car train at a Magistrale Elevator = 15 second = 0.25 minutes
- 60 minutes /0.25 minutes = 240 trains/ hour
- Both the Area stockers and Magistrale elevators can handle the amount of lots required per hour in the above table. The most lots required will be from area stockers 5 to 1 or 1 to 5 at 128 lots (127.18 lots per hour as above).

Therefore, the Area Stocker operators would have to load and unload trains = 128 lots in one hour / 60 minutes = 2.13 minutes or 2 minutes and 7.8 seconds to keep up with the maximum load.

The total maximum number of possible moves in an hour for the six Area Stockers is 805 lots.

Floor	Stocker	H15-4	H17	H16	H16	H15-3	H15-5	Totals
		1	2	3	4	5	6	
H15-4	1	0	480	235	325	105	83	1229
H17	2	480	0	520	610	490	468	2570
H16	3	235	520	0	365	245	223	1591
H16	4	325	610	365	0	335	313	1952
H15-3	5	105	490	245	335	0	93	1273
H15-5	6	83	468	223	313	93	0	1184
	Total	1229	2570	1591	1952	1273	1184	9796

Table 3. Actual Travel Distance (feet) From-To-Table

The above (Table 3.) shows the travel distance in feet between each Area Stocker, used to calculate the amount of travel time, table 4., between Area Stockers.

Floor	Stocker	H15-4	H17	H16	H16	H15-3	H15-5	Total
		1	2	3	4	5	6	
H15-4	1	0	10	7	8	5	5	34
H17	2	10	0	11	12	10	10	52
H16	3	7	11	0	8	7	7	39
H16	4	8	12	8	0	8	8	44
H15-3	5	5	10	7	8	0	5	36
H15-5	6	5	10	7	8	5	0	35
	Total	34	52	39	44	36	35	241

Table 4. Train Travel Time Between Stockers (min.)

From-To-Table

The above (Table 4.) shows travel time between each Area Stocker. This was done by converting the travel distance between each Area Stocker to centimeters then multiplying the travel distance by the average speed of the trains (40cm/sec).

Floor	Stocker	H15-4	H17	H16	H16	H15-3	H15-5	Total
		1	2	3	4	5	6	
H15-4	1		1	6	6	11	10	34
H17	2	1		16	16	1	1	34
H16	3	6	16		2	6	6	34
H16	4	6	16	2		6	6	34
H15-3	5	11	1	6	6		10	34
H15-5	6	10	1	6	6	10		33
	Total	34	34	34	34	34	33	203

Table 5. Total Travel Time (min.) From-To-Table

The above (Table 5.) is the addition of all area stockers and Magistrale elevators that a train encounters on a move including load and unload times listed below:

- Elevator up or down stroke is 5 seconds
- Elevator load is 5 seconds
- Elevator unload is 5 seconds
- Stocker total move (upstroke or down-stroke + load plus unload) is 15 seconds
- Area Stocker transfer time to and from trains (minutes)
Average is 10 seconds = 1 minute 45 seconds/train

The above (Table 5.) adds to the existing "Travel Time Between Area Stockers" and the "Total Time Per Move" in minutes to determine the total time required. The lightly shaded area indicates the longest moves in time. Note: In order to go from any area stocker to Area Stocker 3 you must bypass Elevator 2 because they are both on the

same loop, which explains the longer times associated with trains going to H-16-B (Building 16, 2nd floor - Test & LCT).

Statistical Analysis:

This statistical analysis was required to determine:

- 1) Number of trains required by the 6 Area Stockers based on the total lot moves per Hour, assuming 1, 2 and 3 lots on average per train.
- 2) Run the simulation with a maximum of 50 trains to determine the utilization of each of the trains.

First calculate the maximum number of trains required, see Table 6.

To get the maximum we load each train with the minimum number of lots, one lot per train. The actual number of trains will be lower than this number because the average number of lots traveling on a train should be greater than 1.

Floor	Stocker	H15-4	H17	H16	H16	H15-3	H15-5	Total
		1	2	3	4	5	6	Trains
H15-4	1							
H17	2	1						
H16	3	1	3					
H16	4	7	7	1				
H15-3	5	6	1	1	4			
H15-5	6	1	1	1	1	1		
	Total Trains	16	12	3	5	1	0	37

Table 6. Maximum Trains w/1 Lot per Train From-To-Table

The lot moves per hour was multiplied by the total travel and move times to determine the total time for all moves in minutes. The total number of trains calculated by dividing the above total time for all moves in minutes by 60. This result is the percentage per hour an Area Stocker requires to service a train. If the percentage is:

- >0.00 and < 1.00 then 1 train is required an hour;
- >1.00 and < 2.00 then 2 trains are required per hour;
- >2.00 and < 3.00 then 3 trains are required per hour;
- >3.00 and < 4.00 then 4 trains are required per hour,

The largest amount is taken from the From-To or To-From cell and put in the lower left quadrant. The highest number was taken because more lots may be traveling From-To than To-From. Each cell was rounded up to the nearest integer because you cannot have a fraction of a train. To get the maximum we only loaded one lot per train. The table shows the maximum number of trains required is 37. Each loop has the number of trains required given the moves for their respective areas. For example loop 4 to 2 or 2 to 4 the maximum number of trains required is 7. To get the maximum we only loaded one lot per train. If we loaded two or three lots per train on average, we would go through all of the above calculations to get a number below 50 trains. Here (Table 7.) shows the results for three (3) lots on average per train and the maximum number of trains required being 20.

Floor	Stocker	H15-4	H17	H16	H16	H15-3	H15-5	Total Trains
H15-4	1	1	2	3	4	5	6	0
H17	2	1						1
H16	3	1	3					4
H16	4	1	4	1				6
H15-3	5	1	1	1	1			4
H15-5	6	1	1	1	1	1		5
	Total Trains	5	9	3	2	1		20

Table 7. Maximum Trains w/3 Lots per Train From-To-Table

The table above (Table 7.) shows how often trains are required by each From-To cell for each of the 37 trains total for all loops. For example, area Stocker 1 requires 16 trains total; 12 trains for area Stocker 2, 3 train for area Stocker 3, 5 trains for area Stockers 4 and 1 train for area Stocker 5.

The simulation was run with a maximum of 50 trains to determine the utilization of each of the trains. If a train was not required, it was not used. It was determined that a maximum of 37 Trains were required to transfer 1 Lot per Train. The simulation also demonstrated the use or non-use of a train; therefore 20 trains were required when the average number of Lots per Train was three.

See the train utilization's Table 8 below. The utilization for each train on the loop and stocker capacity was calculated using all the above assumptions in a simulation model running the equivalent of one half a year (182 days) with a 95% confidence level (see Figures 7 and 8).

Floor	Stocker	H15-4	H17	H16	H16	H15-3	H15-5	Total Trains
H15-4	1							
H17	2	1 82%						1
H16	3	1 76%	3 83%					4
H16	4	1 79%	4 85%	1 79%				6
H15-3	5	1 71%	1 83%	1 77%	1 80%			4
H15-5	6	1 70%	1 83%	1 76%	1 79%	1 71%		5
	Tot Trains	5	9	3	2	1		20

Table 8. Maximum Train Utilizations w/3 Lots per Train From-To-Table

The from to calculations on excel shows that 37 trains would be sufficient to meet the requirement of lot moves per hour between the 6 area stockers if the average was 1 Lot per Train (1 lot/6 lots per train = 16% utilization assumed) and that if on average if you had 3 lots per Train 20 trains (3 lot/6 lots per train = 50% utilization assumed) would be sufficient. When we ran the simulation model with the minimum amount of 20 trains we calculated the average utilization of each of the trains over 182 days the answer is in Table 8.

This confirms that given the From –To table that 20 trains would be able to handle all the “Lot” or “Cassette” Moves.

Here are some views of From-To loops and stockers that ran for 182 days for calculating the utilization rates.

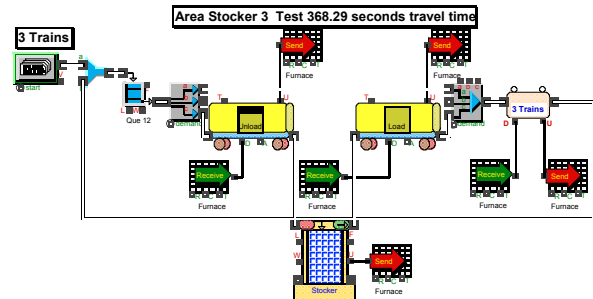

Figure 7. Stocker 3 – Test

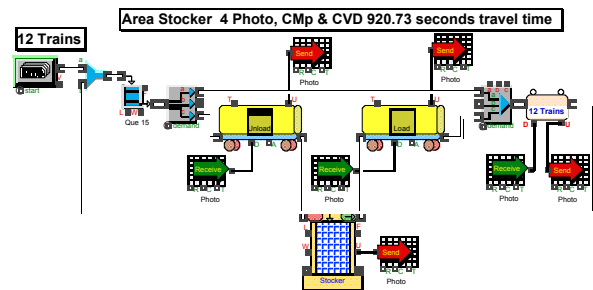

Figure 8. Stocker 4 – CMP, CVD & LIT

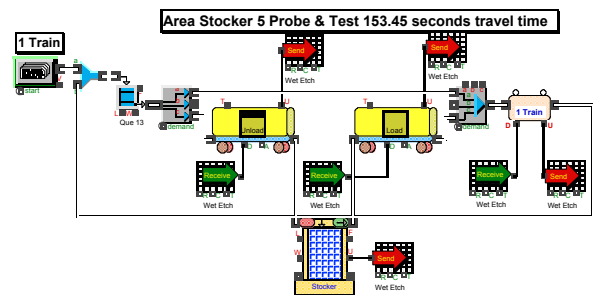

Figure 9. Stocker 5 – Probe and Test

The Area Stockers for Stocker 1, Stocker 2 and Stocker 6 are similar to the above Icon sets except they differ in the number of Trains.

Conclusions

The estimated maximum number of trains required to service the 6 Area Stockers and meet number of lots required by “customer’s FAB = 37 trains with a Maximum number of moves in an hour for all six Area Stockers = 804 moves/hour (assumes the possibility of only one lot per train). The maximum load on any Area Stocker = 128 moves/hour* (Assumes the possibility only one lot per train) and the maximum Utilization of Trains (assuming 37 trains) = 94.8%. The

bottleneck Area Stocker 4 for CMP, CVD and Photo Lithography require the most service by Trains.

The Simulation Model was developed using the Extend+Manufacturing™ simulation software from Imagine That, Inc., San Jose, CA. and the ACADZ AMHS Libraries™ produced by ACADZ inc., Phoenix Arizona.

Bibliography

Brett A. Peters and Taho Yang, "Integrated Facility Layout And Material Handling System Design In Semiconductor Fabrication Facilities", IEEE transactions on Semiconductor Manufacturing, Vol. 19, No. 3, August 1997.

Mitchell Weiss, "300mm Automation Technology Option and Selection Criteria", 1997 IEEE/SEMI Advanced Semiconductor Manufacturing Conference, p. 373, 1997

D.W. Collins, V.J. Lakshman, L.D. Collins, "Dynamic Simulator for WIP Analysis in Semiconductor Manufacturing," *Proceedings of ISSM'2001 Conference*, San Diego, CA., Oct, 2001.

D.W. Collins, F. Golshani, F. Hoppensteadt, C. Ringhofer, J. SI and K. Tsakalis, "Interdisciplinary Research on Modeling and Scheduling of Semiconductor Manufacturing Operations," *Proceedings of ASEE'2000 Conference*, St. Louis, Missouri, June 18-21, 2000.

Authors:

Donald W. Collins is the Director of R & D and founder of ACADZ, inc. He is the inventor of Minimum Inventory Variability Scheduling and Release Policy® (MIVP®). The cycle time for a process and its work-in-process (WIP) inventory are linked, so that improvements in the efficiency of a process can be measured by either cycle time or inventory. The MIVP® policies eliminate the instantaneous inventory build-ups that develop when there is any unplanned interruption in a manufacturing process. At ACADZ he also has developed hardware for inventory tracking and icon based simulation software for modeling complex manufacturing systems such as electronics and semiconductor multiple product factories. During his career in manufacturing and simulation he has worked with and/or consulted to NASA, SEMATECH, Advanced Micro Devices, Motorola, Intel, NEC, Sanyo, Seiko Epson, Infineon and Hitachi.

He is also a Professor of Engineering Technology in the Department of Manufacturing and Aeronautical Engineering Technology at Arizona State University East Campus, Mesa, AZ. His research interests are in manufacturing simulation, scheduling, modeling, and computer graphics. To date he has published over 40 papers on the subject manufacturing simulation. Professor Collins received his

Ph.D. and MS degrees from the Electrical Engineering Department at the University of Illinois at Chicago Circle, 1980 and 1975 respectively. He began his real world simulation experience with NASA, simulating the deployment of satellites from the Space Shuttle. He is a member of AeA, ACM, ASEE, SIGGRAPH, SME and NAIT.

Luc D'Arcy Collins is president and founder of ACADZ inc. Since becoming president of ACADZ inc. he has established three patented products in addition to the already existing efficiency manufacturing consulting business. The icon based simulation software, inventory tracking hardware and software and a medical product for cancer treatment.

Prior to working with ACADZ Luc D'Arcy Collins was director of operations management for a developer for a technology park and successfully wrote a plan that raised over 3 million dollars in capital funding. Prior to this position he has worked at Motorola in Budgeting in the area of Research and Development; for the Overseas Private Investment Corporation, in Washington DC, in International Loan Restructuring; and for a Manufacturing Company of specialized products for cancer treatment.

His interests include financial analysis and cost reduction for multiple product manufacturing including semiconductor, electronics, and medical manufacturing industries. He has written papers on semiconductor factory production capacity measurement and planning using static capacity models verses dynamic simulation models.

After the completion of a Bachelors of Science (Finance) Degree from Arizona State University, Collins received a Master of International Management from the American Graduate School of International Management (Thunderbird).

Bob F. Franklin is Vice President Worldwide Sales at Intrabay Automation. Intrabay Automation, Inc. is an emerging leader in automated material handling systems, providing world-class products and innovative solutions to semiconductor manufacturers and OEMs. The company's stockers, buffers, monorail transport system and factory automation software store, retrieve and track wafers and reticles throughout the manufacturing process. Bob F. Franklin has more than twenty years of sales and marketing experience in the semiconductor industry. Prior to joining Intrabay Automation in 2001, he served as Vice President Worldwide Sales & Marketing at MTI, establishing a new market in the semiconductor industry. Prior to MTI, Bob was Director of Sales at Ultratech Stepper, where he grew the company to \$185 million in sales. His other experiences include: Regional Sales Manager at Canon, USA, Sales Engineer at Perkin-Elmer and Product Marketing Manager at Texas Instruments, Inc. Bob holds a Bachelor of Science in Business from S.E. Oklahoma State University.